

# CURRENT TRANSFORMER

Model 781

Window Diameter 6.5"

**Application:**  
Relaying and metering

**Frequency:**  
50 - 400 Hz

**Insulation Level:**  
600 Volts, 10 kv BIL full wave

**Continuous Thermal Current Rating Factor:**  
2.0 at 30°C amb., 1.5 at 55°C amb.

- Secondary terminals are No. 10 - 32 brass screws with one flatwasher, lockwasher and regular nut.

- Approximate weight: 31 lbs.



E228202

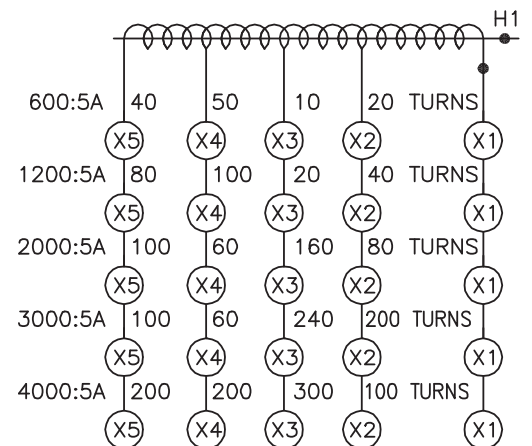
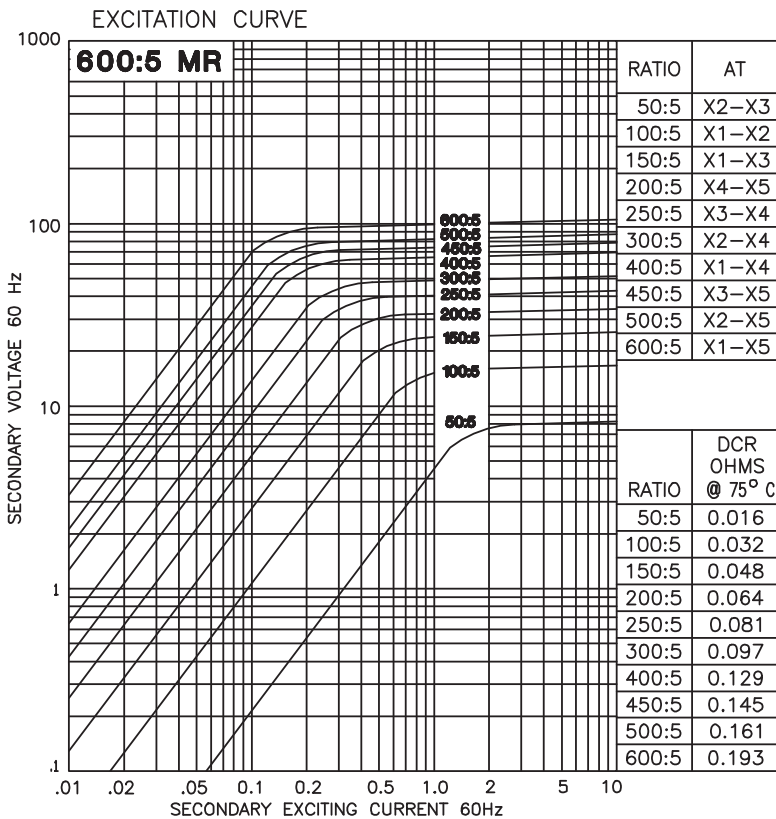
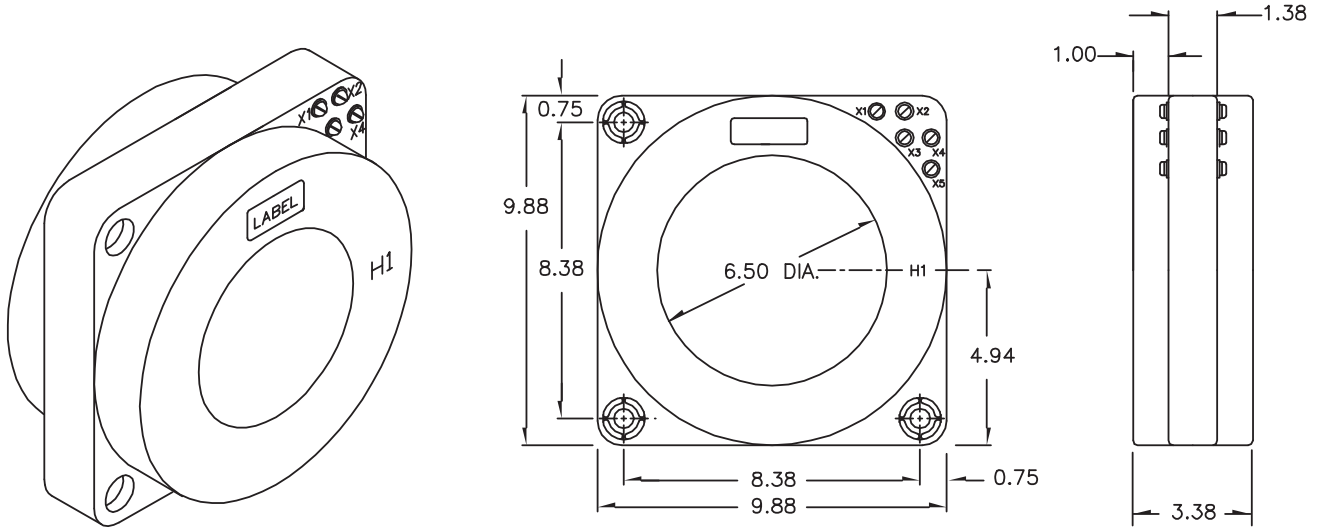

CONNECTION DIAGRAM

MODEL 781 - 601MR - rating C100

# Typical Excitation Curves - Model 781

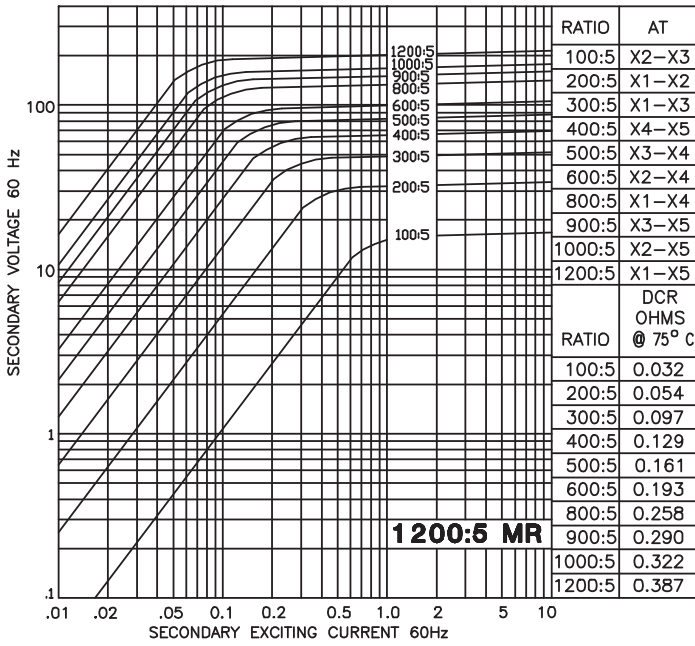

**MODEL 781 - 122MR - rating C200**

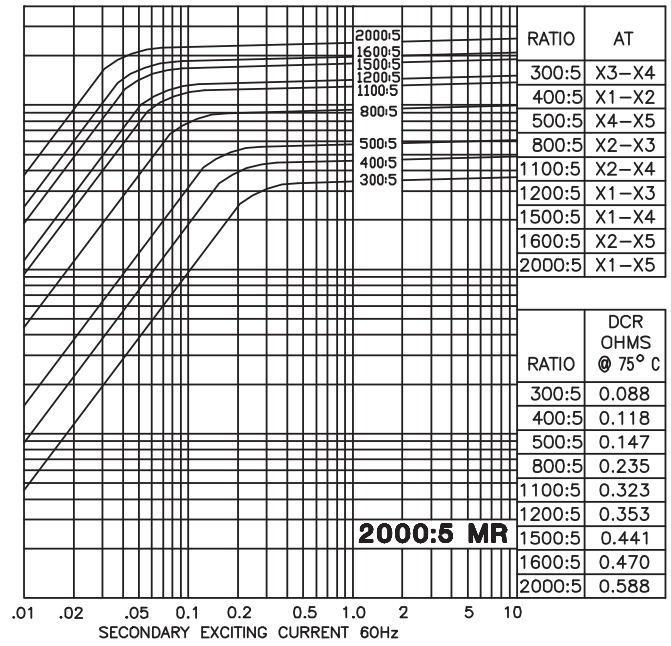

**MODEL 781 - 202MR - rating C200**

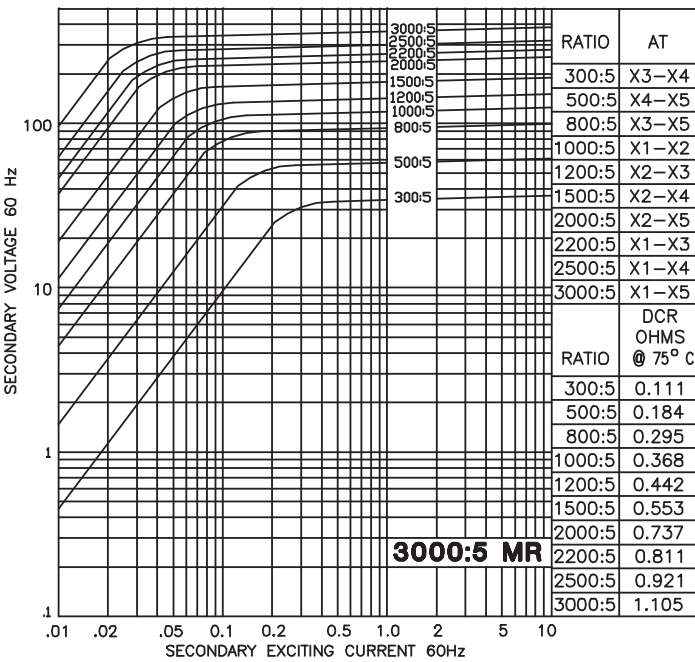

**MODEL 781 - 302MR - rating C200**

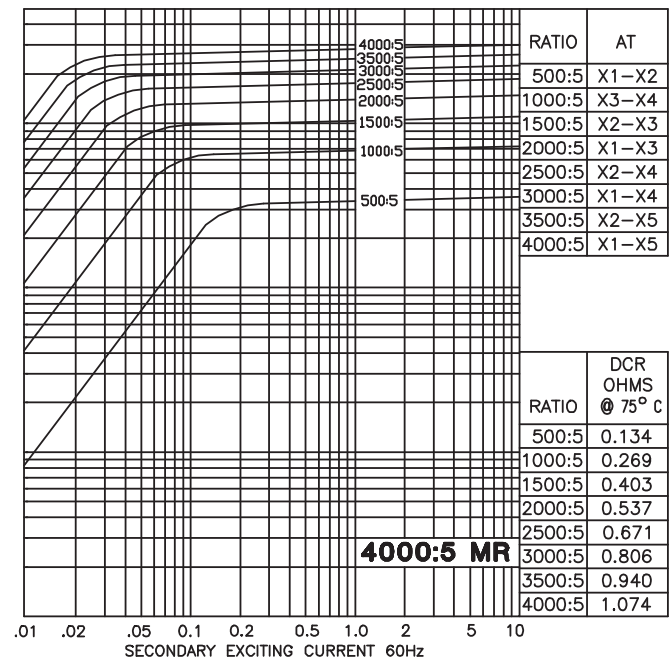

**MODEL 781 - 402MR - rating C200**